

LIFTMASTER®

MAGIC BUTTON FS10 & LPK5 FAST SLIDER

OPERATORS MANUAL

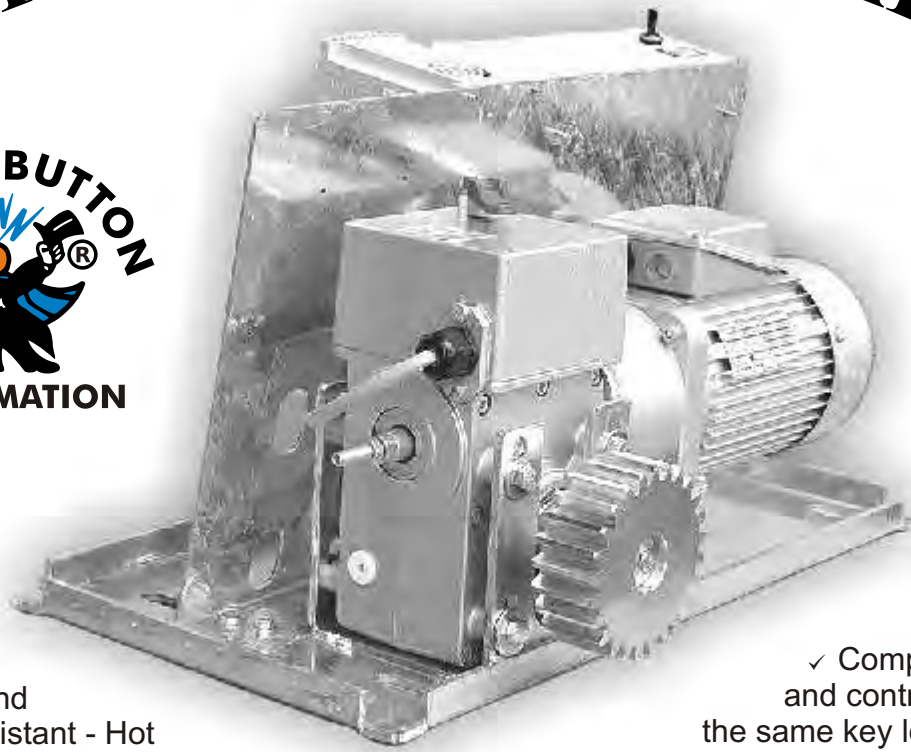

FEATURES

- ✓ High speed
-800mm/second
- ✓ Corrosion resistant - Hot dip galvanised base with stainless steel cover
- ✓ Speed flexibility - Slow start / slow stop with fast open - slow close for additional safety
- ✓ Compact - Motor and controls all under the same key lockable cover
- ✓ Safety - An inbuilt clutch and isolation switch under the cover
- ✓ Emergency use - Simple motor disconnect for power fail situations
- ✓ Voltage - 240V supply

WARNING

This equipment requires installation by persons with appropriate electrical qualifications and training and must be wired in accordance to AS3000 wiring rules





TABLE OF CONTENTS

1.	FS10 INSTALLATION	page 3-4
1.1	Preliminary Checks		3
1.2	Installing the Operator		3
1.3	Fixing the Drive Rack		4
2.	LPK5 INSTALLATION	5-6
2.1	Preliminary Checks		5
2.2	Installing the Operator		5
2.3	Fixing the Drive Rack		6
3.	ELECTRICAL	7-9
3.1	Wiring Connections		7
3.2	Step Down Limit Configuration		8
3.3	Control Board Instructions		8
3.4	Photo Electric Wiring		8
3.5	Speed Inverter Instructions with Step Down Speed		9
4.	Limits	10
4.1	Limit Switch Function		10
4.2	Setting the Limits		10
5.	GENERAL MAINTENANCE & SETUP	11
5.1	Disengagement Lever		11
5.2	Slipping Clutch		11
5.3	Safety		11
5.4	Lubrication		11
6.	TROUBLE SHOOTING	12
6.1	Fault Finding Guide		12
7.	PARTS EXPLOSION	13-14
7.1	FS10 Parts List		13
7.2	LPK5 Parts List		14
8.	F.A.Q	15
8.1	Frequent Question		15



1. FS10 INSTALLATION

1.1 Preliminary Checks

To ensure trouble free operation, make sure that the gate (whether existing or to be installed) has the following specifications.

- Strong and rigid gate frame manufactured to appropriate engineered standards
- The gate moves freely and evenly over its entire travel and does not jam on start up from either direction - especially with cantilevered gates
- No sideways oscillation movement of the leaf
- Upper and lower sliding system in perfect condition with appropriate rated wheels and rollers
- Adequate mechanical gate stops which have been appropriately engineered are mandatory
- The gate has sufficient extension for mounting the drive rack (Fig. 1)

If any welding or brazing is required on the gate, it should be done before installing the automation system. The condition of the structure directly affects the reliability and safety of the automation system

1.2 Installing the Operator

1. Lay the conduits and cables between operator, accessories and power supply. The flexible pipes must protrude approx. 2cm from the cable entry hole. To facilitate the electrical wiring on the electronic system, leave about 45cm of free cable out of the bore in the base plate.
2. Unpack the operator and check that all accessories are included in the parcel.
3. Open the cover of the operator by means of the key supplied.
4. Place the base plate in the position shown at Fig. 1 (for left or right hand mounting).
5. Ensure surface is perfectly level and mark the bolt hole positions; These should be positioned in the slot at the further most point away from the gate (This is to allow the operator to be slid in and out of the drive rack). Remove operator and drill for bolting down with 4 x 12mm x 100mm Dyna bolts or equivalent. Before bolting down place 2mm shims, as a temporary measure, between the ground surface and the base plate. These are to be removed after the rack has been correctly attached to the gate (See 1.3).
6. Connect the cables to the electronic control unit (refer to section 3).

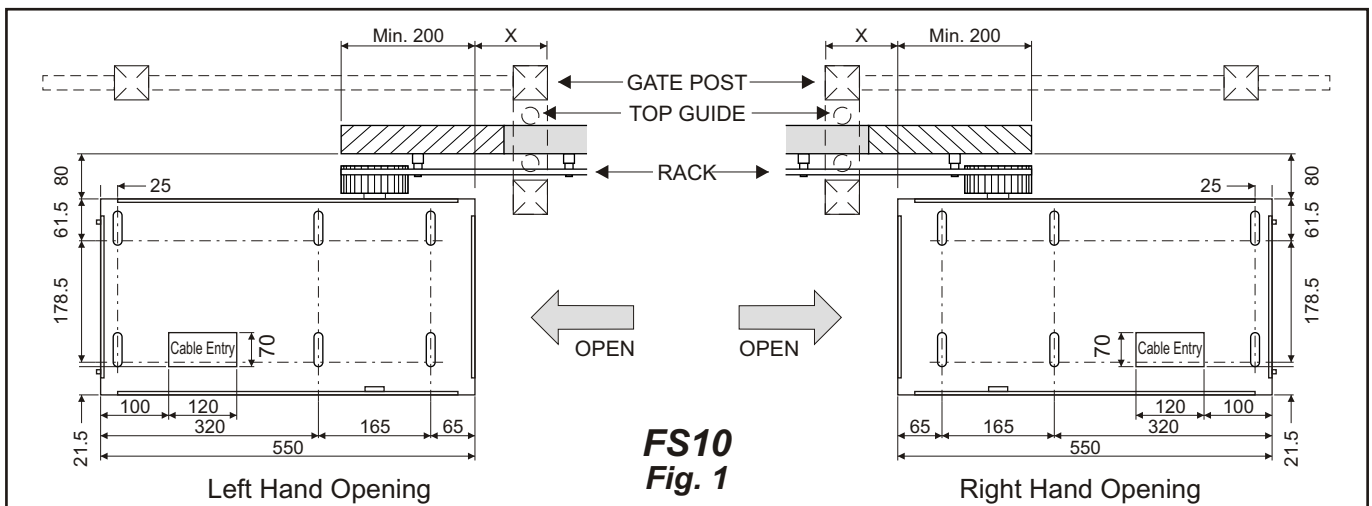



1.3 Fixing the Drive Rack

- Fit the rack by means of:
 - 12g tek screws for Nylon rack (not supplied).
 - the supplied screws for Steel rack.

It is advisable to tighten the rack fixing screws at the centre of the slot. This allows the rack to be adjusted up and down if gate drop occurs.

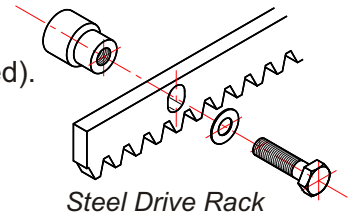

- Release the operator as shown in Fig.13
- Slide gate leaf open by hand.
- Place the first section of the rack on the pinion, aligning it with the first spacer (tab on nylon rack).
- Fix the rack section to the leaf by means of a clamp.
- Slide the gate leaf by hand towards its closed position, until it is in line with the last spacer/tab on the rack and spot weld the spacer in position (Screw the tabs for the nylon rack).

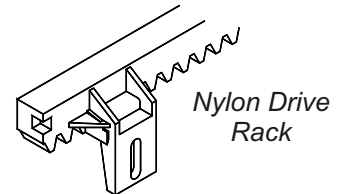

Fig. 2

- For the steel drive rack, completely weld the three spacers to the gate. To fasten the other rack sections needed to reach the position of complete closing, proceed as follows.
- Line up another drive rack length to the last one fixed on the gate. Use a section of rack of about 150mm long and clamp this section to the two lengths of drive rack to ensure that the teeth correctly mesh (Fig.4).
- Slide the gate leaf by hand towards its closed position until the third spacer of the section to be fastened is aligned with the pinion (Fig. 4). Weld the three spacers to the gate. Repeat this process until all rack is installed.

Ensure that all the rack sections are correctly centred on the pinion teeth (Fig. 3). If not, adjust the position of the operator. Do not weld the rack sections to the spacers or to each other.

Fig. 3

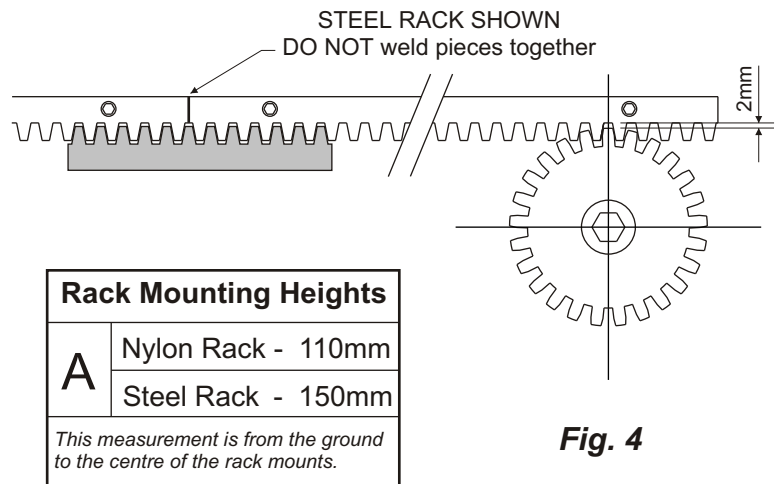
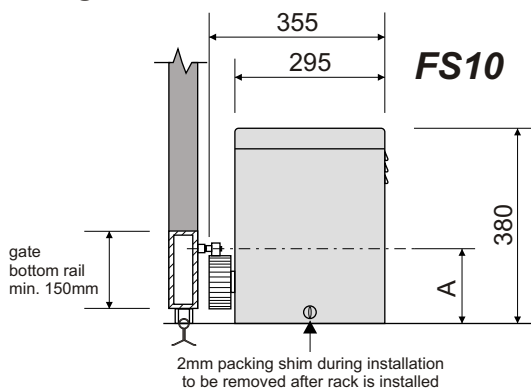

Fig. 4

- Manually check whether the gate can open completely and the movement of the leaf is smooth and even, over its entire travel.

*The slack between the pinion and the rack must be 2mm (Fig. 3 & 4). If the gate is new, check the slack a few months after installation. **Do not** apply grease or other lubricants to the pinion or rack.*

- Check all fixing screws are secure and tight.



2. LPK5 INSTALLATION

2.1 Preliminary Checks

To ensure trouble free operation, make sure that the gate (whether existing or to be installed) has the following specifications.

- Strong and rigid gate frame manufactured to appropriate engineered standards
- The gate moves freely and evenly over its entire travel and does not jam on start up from either direction - especially with cantilevered gates
- No sideways oscillation movement of the leaf
- Upper and lower sliding system in perfect condition with appropriate rated wheels and rollers
- Adequate mechanical gate stops which have been appropriately engineered are mandatory
- The gate has sufficient extension for mounting the drive rack (Fig. 5)

If any welding or brazing is required on the gate, it should be done before installing the automation system. The condition of the structure directly affects the reliability and safety of the automation system

2.2 Installing the Operator

1. Lay the conduits and cables between operator, accessories and power supply. The flexible pipes must protrude approx. 2cm from the cable entry hole. To facilitate the electrical wiring on the electronic system, leave about 45cm of free cable out of the bore in the base plate.
2. Unpack the operator and check that all accessories are included in the parcel.
3. Open the cover of the operator by means of the key supplied.
4. Place the base plate in the position shown at Fig. 5 (for left or right hand mounting).
5. Ensure surface is perfectly level and mark the bolt hole positions; These should be positioned in the slot at the further most point away from the gate (This is to allow the operator to be slid in and out of the drive rack). Remove operator and drill for bolting down with 4 x 12mm x 100mm Dyna bolts or equivalent. Before bolting down place 2mm shims, as a temporary measure, between the ground surface and the base plate. These are to be removed after the rack has been correctly attached to the gate (See 2.3).
6. Connect the cables to the electronic control unit (refer to section 3).

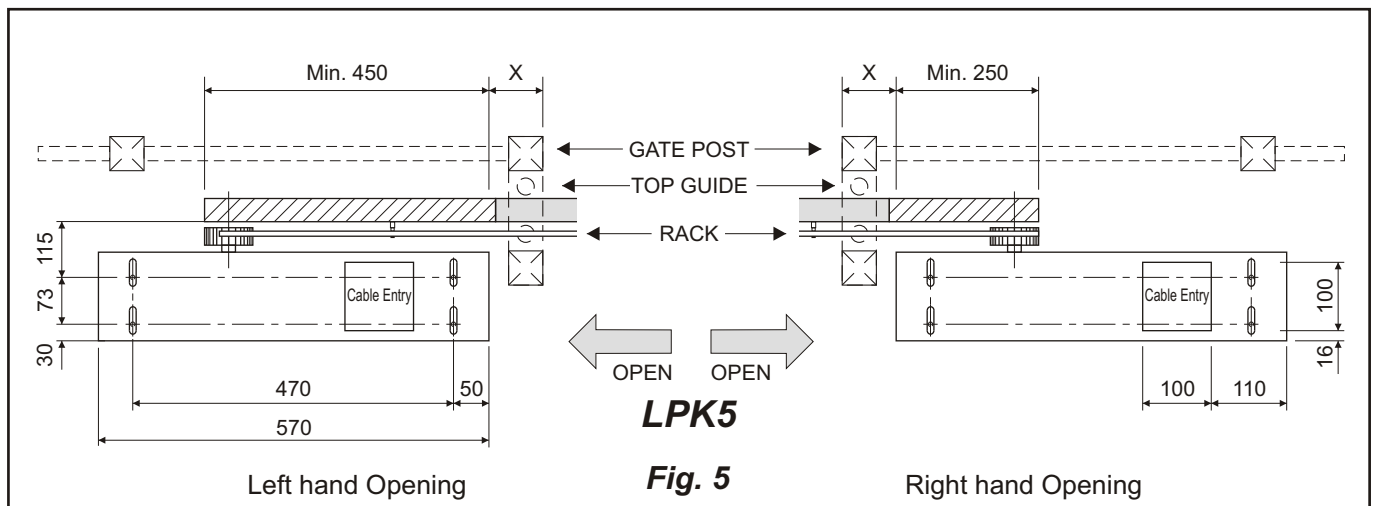



2.3 Fixing the Drive Rack

- Fit the rack by means of:
 - 12g tek screws for Nylon rack (not supplied).
 - the supplied screws for Steel rack.

It is advisable to tighten the rack fixing screws at the centre of the slot. This allows the rack to be adjusted up and down if gate drop occurs.

- Release the operator as shown in Fig.13
- Slide gate leaf open by hand.
- Place the first section of the rack on the pinion, aligning it with the first spacer (tab on nylon rack).
- Fix the rack section to the leaf by means of a clamp.
- Slide the gate leaf by hand towards its closed position, until it is in line with the last spacer/tab on the rack and spot weld the spacer in position (Screw the tabs for the nylon rack).
- For the steel drive rack, completely weld the three spacers to the gate. To fasten the other rack sections needed to reach the position of complete closing, proceed as follows.
- Line up another drive rack length to the last one fixed on the gate. Use a section of rack of about 150mm long and clamp this section to the two lengths of drive rack to ensure that the teeth correctly mesh (Fig.8).
- Slide the gate leaf by hand towards its closed position until the third spacer of the section to be fastened is aligned with the pinion (Fig. 8). Weld the three spacers to the gate. Repeat this process until all rack is installed.

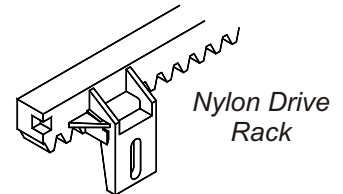
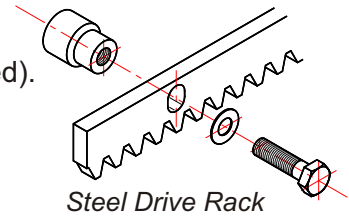
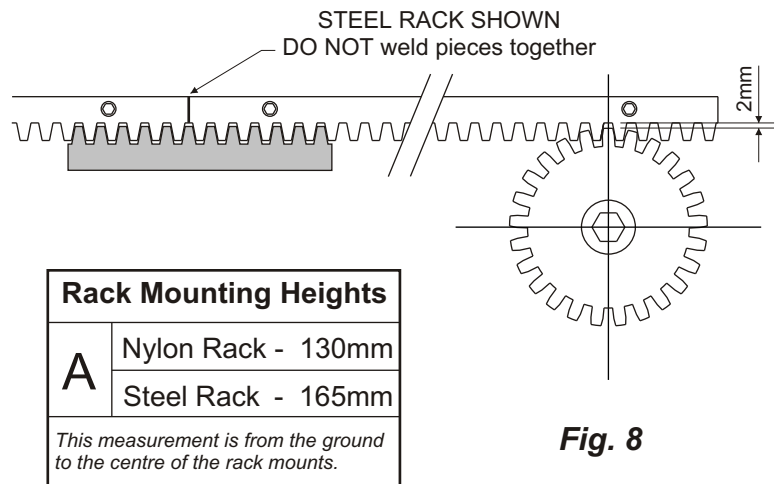
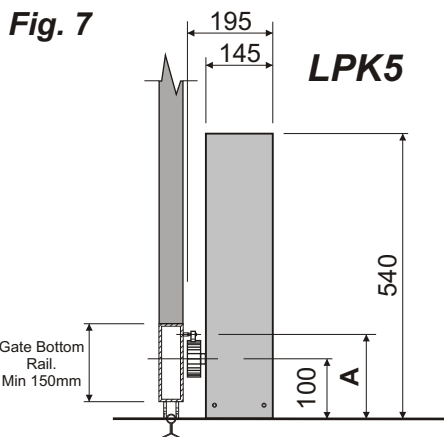

Fig. 6

Ensure that all the rack sections are correctly centred on the pinion teeth (Fig. 7). If not, adjust the position of the operator. Do not weld the rack sections to the spacers or to each other.



- Manually check whether the gate can open completely and the movement of the leaf is smooth and even, over its entire travel.

*The slack between the pinion and the rack must be 2mm (Fig. 7 & 8). If the gate is new, check the slack a few months after installation. **Do not** apply grease or other lubricants to the pinion or rack.*

- Check all fixing screws are secure and tight.



LIFTMASTER

MAGIC BUTTON FS10 & LPK5 FAST SLIDER - OPERATORS MANUAL

3. ELECTRICAL

3.1 Wiring Connections

MB106 WIRING INSTRUCTIONS USING TAIAN E2-201-H1F INVERTER

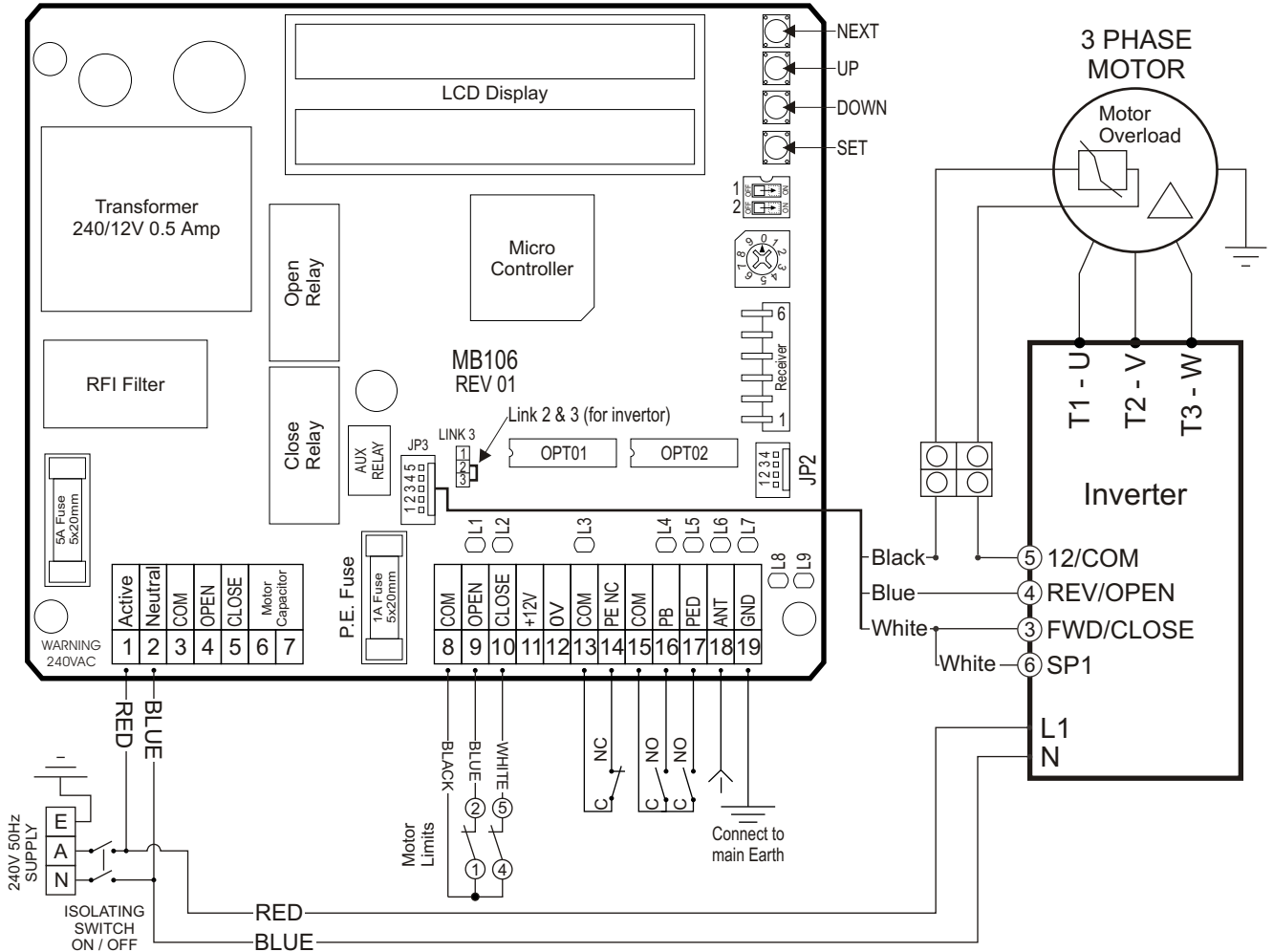

WIRING DIAGRAM FOR STEP DOWN SPEED CONTROL

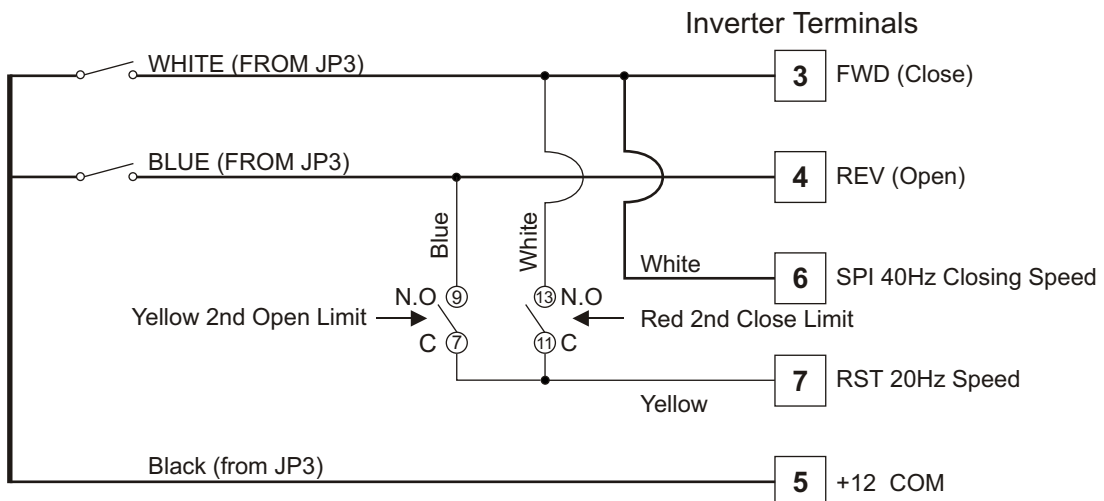

Fig. 9



3.2 Step Down Limit Configuration

Opening: the step down open limit (yellow) is set 10 degrees before the final open limit (green). The yellow limit will start the 2nd speed and the gate will move at 20Hz speed for small distance then the gate will stop on the green open limit.

Closing: the step down limit (red) is set 10 degrees before the final close limit (black). The red limit will start the 2nd speed and the gate will move at 20Hz speed for small distance then the gate will stop on the black limit.

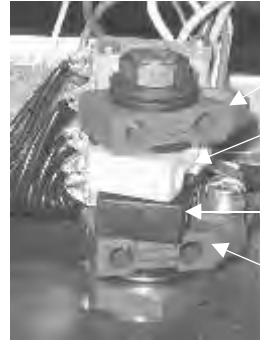

RED, Close step down limit

YELLOW, Open step down limit

BLACK, Close stop limit

GREEN, Open stop limit

For details on adjusting the limits, refer to section 4

3.3 Control Board Instructions

For detailed control board information, please refer to the control board instruction manual.

3.4 Photo Electric Wiring

2.4.1 All photo electrics used with the Magic Button FS10 or LPK5 MUST have an Earth wire connected between 0V supply terminal and the photo electric steel case or any other metal plate next to the photo electric (E.g. Gate jamb, post, track etc)

3.4.2. RIB Photo Electric Wiring (500211)

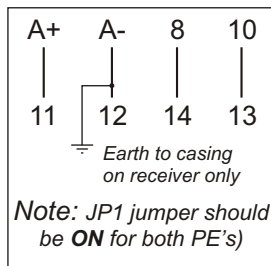

3.4.3. Mini Photo Electric Wiring (500212)

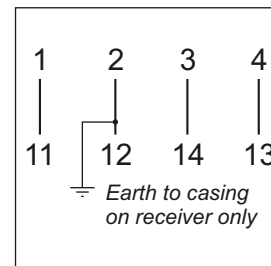

Note: For other brands of photo electrics, refer to the manufacturers instructions



3.5 Speed Inverter Instructions with Step Down Speed

TAIAN INVERTER PROGRAMMING

	SETTING	DISPLAY	COMMENT
1	Turn Power ON	5.0	Running Frequency
2	Press ▲ till 60	60	Set Running Frequency to 60Hz
3	Press DSP FUN	F00	
4	Press ▲ till 1	F01	Acceleration time function
5	Press DATA ENT	05.0	
6	Press ▼ till 1	1	Acceleration time set to 1
7	Press DATA ENT	F01	
8	Press ▲ till 2	F02	Deceleration time function
9	Press DATA ENT	5.0	
10	Press ▼ till 0.5	1	Deceleration time set to 1
11	Press DATA ENT	F02	
12	Press ▲ till F05	F05	
13	Press DATA ENT	1	
14	Press ▲ till 2	2	
15	Press DATA ENT	F05	
16	Press ▲ till F08	F08	
17	Press DATA ENT	10	
18	Press ▲ till 40	40	Closing frequency set to 40Hz
19	Press DATA ENT	F08	
20	Press ▲ till F09	F09	Step down speed
21	Press DATA ENT	6.0	
22	Press ▲ till 20	20	
23	Press DATA ENT	F09	
24	Press ▲ till F10	F10	
25	Press DATA ENT	000	
26	Press ▲ till 1	1	Operating Mode
27	Press DATA ENT	F10	
28	Press ▲ till F13	13	Torque compensation gain
29	Press DATA ENT	000	
30	Press ▲ till 5	5	
31	Press DATA ENT	F13	
32	Press ▲ till F20	F20	
33	Press DATA ENT	05	
34	Press ▼ till 1	001	
35	Press DATA ENT	F20	
36	Press DSP FUN	60	End Programming

Note: These are settings for the running frequency, acceleration time and deceleration time.
Refer to the inverter booklet for other functions.



4. LIMITS

4.1 Limit Switch Function

NOTE: Care should be taken to ensure the limit switch roller does not over travel the limit cam (See Fig. 10). A high speed and long slow down time will cause the motor to over run the limits allowing the gate to continue its travel in the same direction causing damage to the gate and motor.

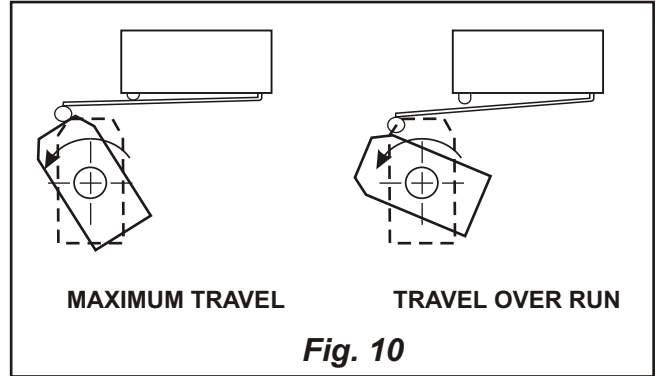

4.2 Setting the limits

To adjust the limits, remove the limit cover (refer to Fig. 14). The coarse adjustment of the limit switches can be done by inserting a rod or screw driver into one of the adjustment holes of the cam wheels and moving in the direction required.

Fine adjustment can be done two ways -
(1) by increasing or decreasing the speed on the inverter, or

(2) by screwing the adjustment screw (refer Fig. 12) against the cam shaft thread inside each cam wheel.

The adjustment screw is supplied inside each limit switch box. The screw must be changed from one adjustment hole to the other for turning the cam wheel in the opposite direction.

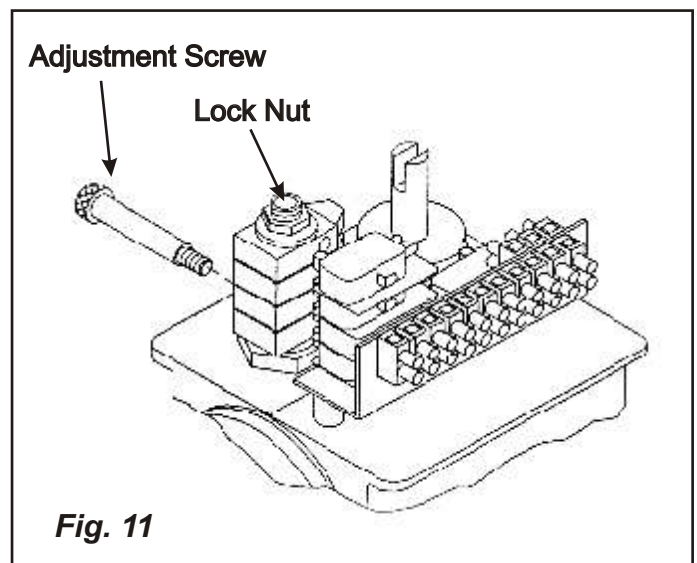

Note: Before starting adjustment of the limit switches, loosen or tighten (if necessary) the lock nut in order to obtain a convenient ADJUSTMENT TIGHTNESS of the cam wheels. After finishing the adjustments, make sure that the lock nut is sufficiently tight to retain the cam wheels during operation (refer Fig. 11)

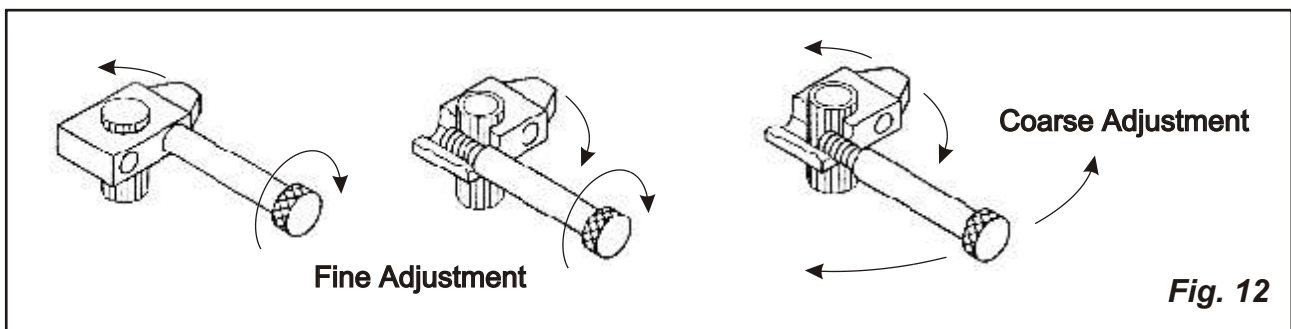



5. GENERAL MAINTENANCE & SETUP

5.1 Disengagement lever

In power failure or emergency situations the disengagement lever is provided to allow the gate to be opened manually. By turning the disengagement lever the gear unit can be disconnected from electric operation in order to permit manual operation of the gate. Before disengagement, isolate the power.

NOTE: When changing the disengagement lever back to electric operation, the gate itself must be moved manually, slightly in either direction in order for the clutch to get perfectly engaged.

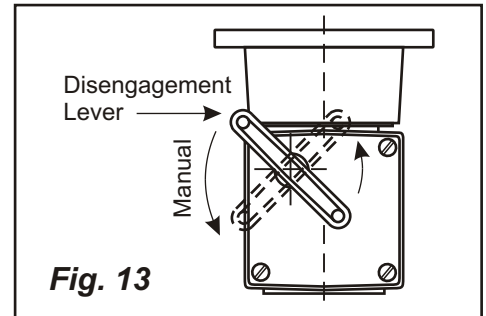

5.2 Slipping Clutch

The torque transmitted by the drive unit must always be adjusted in due consideration of the safety requirements of the gate operation. The limitation of the torque is done by adjusting the slipping clutch.

When supplied from Liftmaster, the slipping clutch is left loose so that no torque can be transmitted from the electric motor.

Adjustment: (Refer Fig. 14)

1. Loosen the lock nut at the end of the worm shaft.
2. Hold the worm shaft with a spanner.
3. Start turning the adjustment screw inwards (clockwise) until the required torque has been obtained.

The torque should be adjusted so that it is just high enough to move the gate over its complete travel and low enough to permit the clutch to slip as soon as the gate is obstructed in its movement. A direct safety risk is produced if the torque is set to a considerably higher level than required for the gate operation.

IMPORTANT: Before starting to adjust the slipping clutch, check and make sure that the gate can easily be moved manually in every part of its travel.

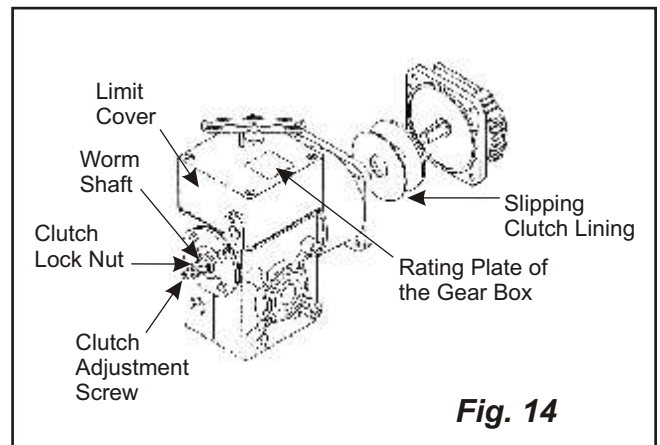

5.3 Safety

The installation of appropriate safety devices applicable for the situation is mandatory. Possible safety accessories include warning signs, photo electrics, vehicle detectors, safety edge profile, emergency stop controls, flashing lights, and traffic lights.

5.4 Lubrication

Correct lubrication is of primary importance for the function of the worm gear. The oil grade of the initial filling is shown on the rating plate of the gear box (refer Fig. 14). In normal operating conditions oil changes are not necessary. The oil quantity, however, should be checked at the time of the installation as well as periodically in connection with normal maintenance and adjustments in the gate function. The red oil plug of the gearbox shows the required oil level.

The normal oil (Mobil Gear Oil 627 or equivalent) is applicable for an environment with temperature variations from -15°C to +45°C. For lubrication in especially low or high operating temperatures we recommend consulting with Liftmaster for appropriate oil.



6. TROUBLE SHOOTING

6.1 FAULT FINDING GUIDE

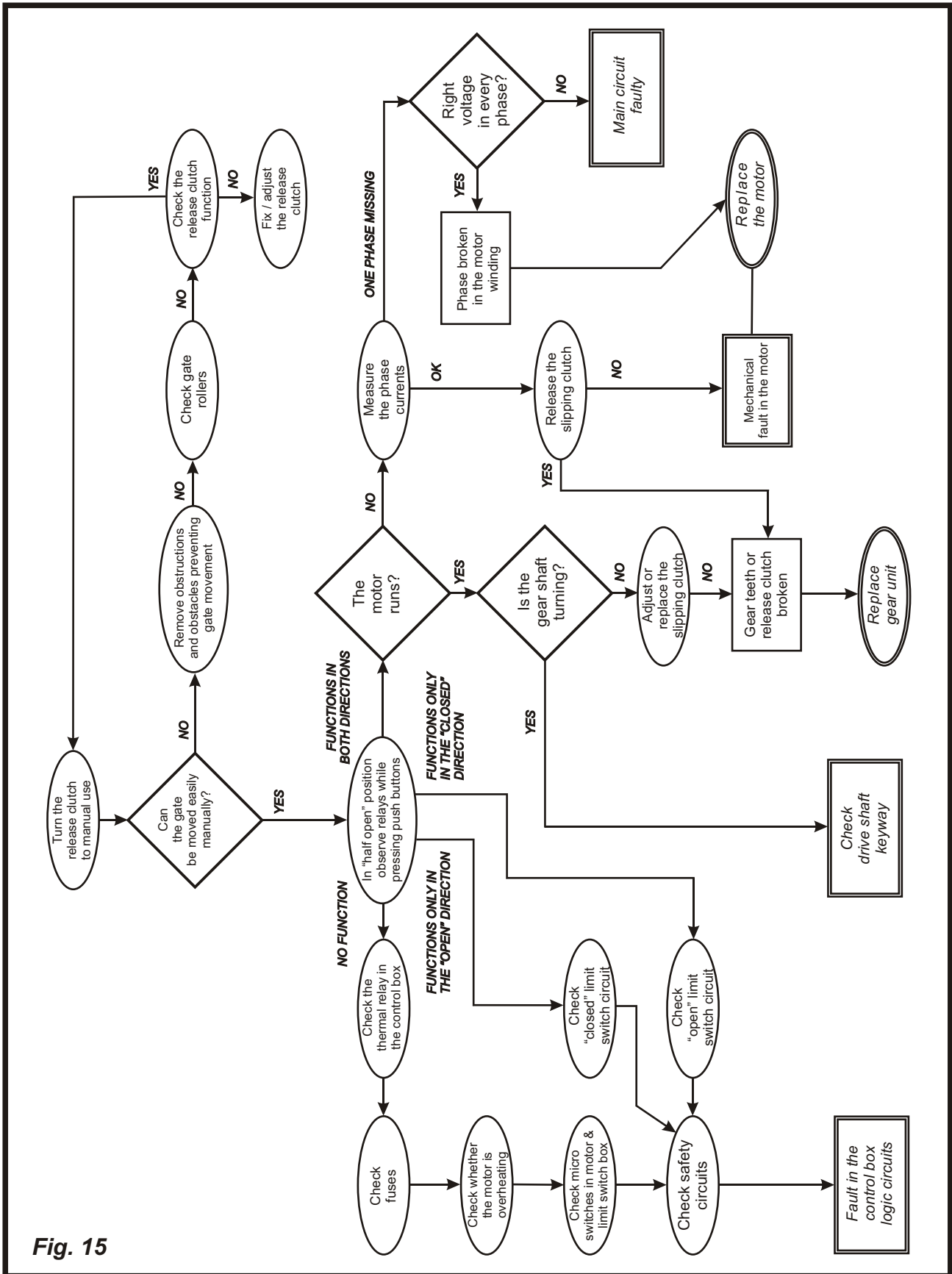

Fig. 15



7. PARTS EXPLOSION

7.1 FS10 PARTS LIST

No.	ITEM	No.	ITEM	No.	ITEM
1	Gear Box & Limit Assembly	5	Lock	9	PVC Control Box
2	Motor 0.55kw	6	Inverter	10	Base Plate
3	Mounting Plate	7	Isolation Switch	11	Sprocket - Z25
4	Cover	8	Magic Button Control Board	12	Shaft

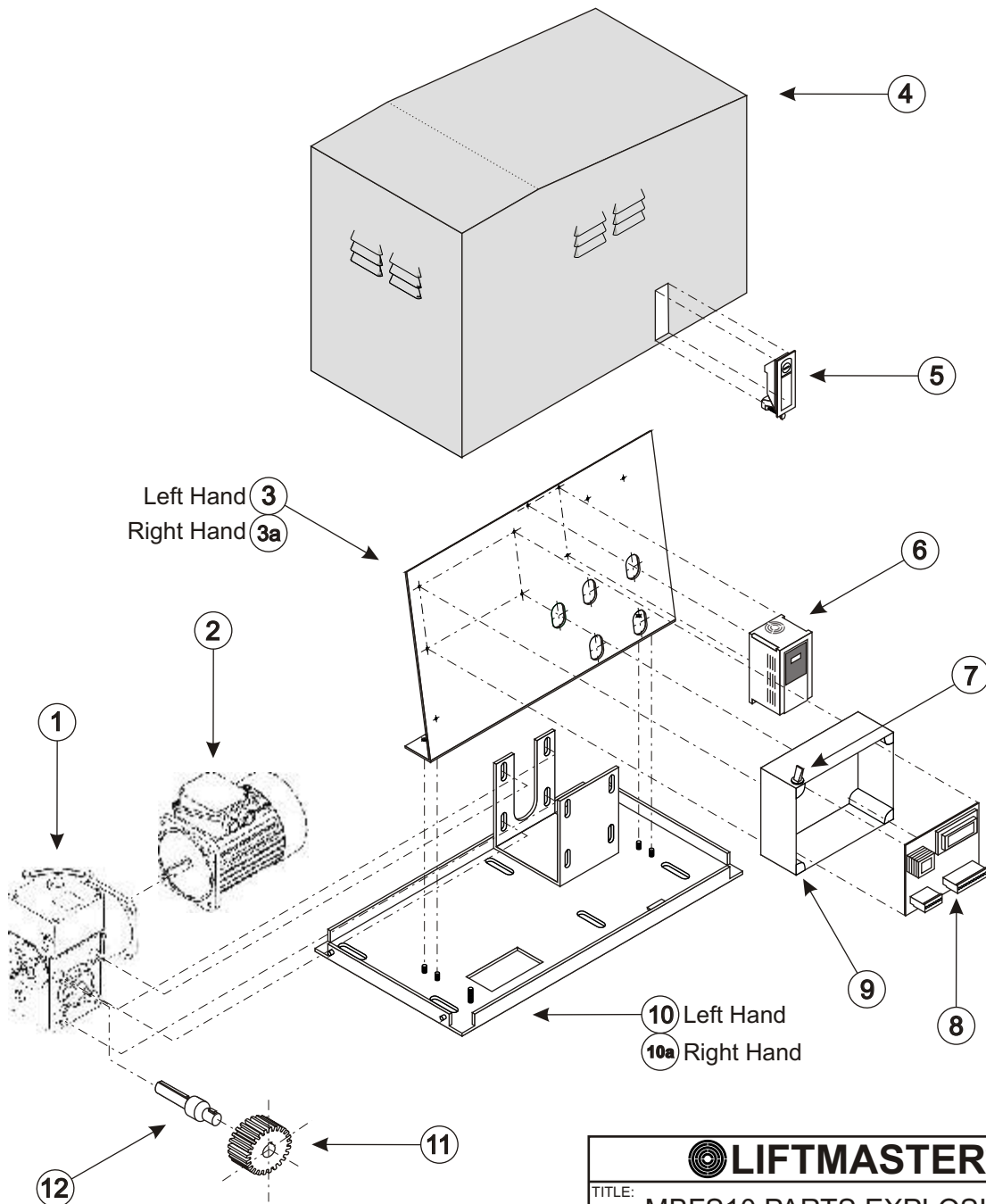

LIFTMASTER®			
TITLE: MBFS10 PARTS EXPLOSION			
	DATE: 08/08/06	DRAWN BY: CF	CHECKED BY: RH
	SCALE: NTS	DRAWING No: spare_parts	



7.2 LPK5 PARTS LIST

No.	ITEM
1	Gear Box & Limit Assembly
2	Motor 0.55kw
3	Base Plate
4	Cover
5	Isolation Switch
6	Control Box - PVC
7	Magic Button Control Board
8	Inverter
9	Shaft
10	Sprocket - Z25
11	Mounting Plate (optional)

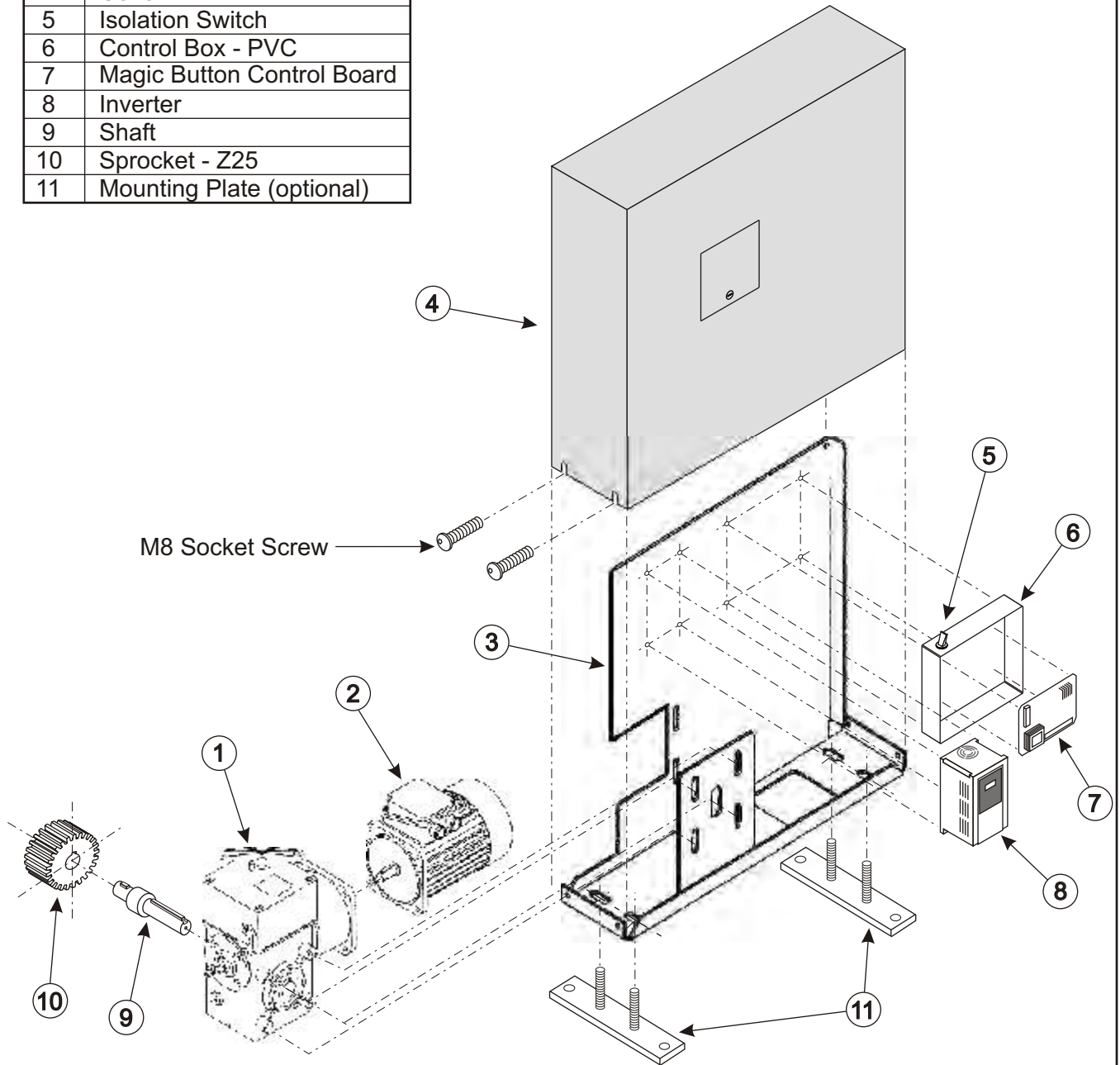

LIFTMASTER ELECTRONICS P/L			
TITLE: OVITOR LPK5 EXPLOSION			
	DATE: 25/2/04	DRAWN BY: DS	CHECKED BY:
	SCALE: NTS	DRAWING No: ovi-lpk5exp.304.ds	



8. F.A.Q.

8.1 FREQUENT QUESTION:

What size and weight gate can this operator handle and how fast does it close/open?

ANSWER:

Gate weight is often used as a criteria for gate motor selection. The first issue of gate motor selection is whether the gate is well engineered, manufactured and installed and can be moved by a force of 400 kiloponds (approximately what one man can move by hand) These requirements are fundamental to every gate installation. The start torque of the FS10 at 50Hz is 144 kg with the 36:2 gearbox or 196 kg with the 29:1 gearbox, and as such the FS10 has a start torque that far exceeds 400 kiloponds.

Gate weight becomes of concern when safety needs are examined, as any fast moving gate, regardless of weight, needs to have sufficient safety devices to provide a prudent operation. Any risk assessment of gate speed involves the potential need of how to stop the gate mass, if required, before it meets the end limits and the mandatory, suitably engineered to suit, open and close gate stops.

As the gate motor speed is achieved by an inverter there will ALWAYS be approximately one (1) second of slow down before the gate motor will be without power and the motor brake engages. A risk assessment of the distance the gate will travel in one second is dependent upon the selected inverter frequency selection and must be taken into account..

The heavier the gate, the more the gate speed should be lowered to achieve an acceptable stopping distance for the application, in the event of an emergency stop. The speed can be altered by lowering the frequency, at 80Hz the gate speed with a 36:2 gearbox is 800mm / sec. , and at this speed the mass of any size gate will be hard to stop in an emergency. Over travel before stopping will be significant, while the slower the speed the less the over travel. This contingency has to be taken into account in any installation, as also the possibility of programming separate speeds for open and close cycles.

The 36:2 gearbox is standard, while the 29:1 gearbox is available on special order.

Gate travel of over ten (10) metres will require four (4) external limits to be installed.

If in any doubt with regard to any issue consult a qualified engineer.

TECHNICAL DATA

Power Supply Required	240V AC
Absorbed Power (Watts)	550 W
Current Drawn (Amps)	4 Amp
Electric Motor	4 Poles - 1370 RPM
Standard Reduction Ratio	36 : 2
Max Speed with 36:2	800mm/sec
Start-up Torque with 36:2	144 kg
Nominal Torque with 36:2	91 kg
Locking Torque with 36:2	80 kg
Optional Reduction Ratio	29 : 1
Max Speed with 29:1	480mm/sec
Start-up Torque with 29:1	196 kg
Nominal Torque with 29:1	124 kg
Locking Torque with 29:1	326 kg
Pinion Size	Z25 (110mm diam.)
Rack	Module 4
Type of Oil	Mobil Gear 627 (or equivalent)
Temperature Range	-15°C to +45°C
Weight of Operator	42 kg





LIFTMASTER

MAGIC BUTTON FS10 & LPK5 FAST SLIDER - OPERATORS MANUAL

NOTES



DISTRIBUTED BY:

LIFTMASTER ELECTRONICS PTY LTD A.B.N. 58 000 266 035
PO BOX 54 ALEXANDRIA NSW 1435 AUSTRALIA **PH: 61 2 9699 9654** **FX: 61 2 9699 8443**
www.liftmaster.com.au

As Liftmaster Electronics policy is one of constant improvement, we reserve the right to alter any part of these specifications without notice and without incurring any obligation.